

CUL-DE-SAC

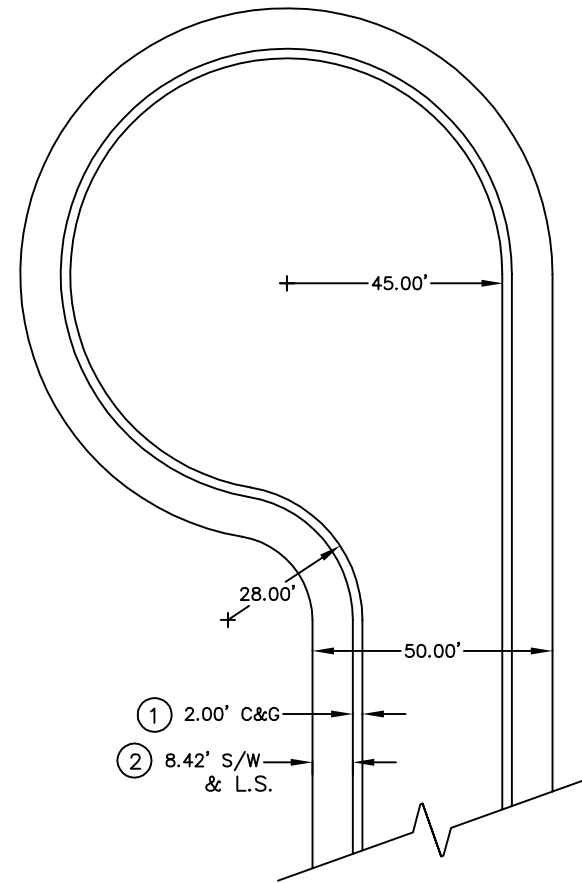

MODIFIED CUL-DE-SAC

NOTES:

- 1 ROLL CURBING MAY ALSO BE USED BUT A MINIMUM WIDTH OF 33.16' FROM B/C TO B/C MUST BE MAINTAINED.
- 2 DETACHED OR ATTACHED SIDEWALKS MAY BE USED.

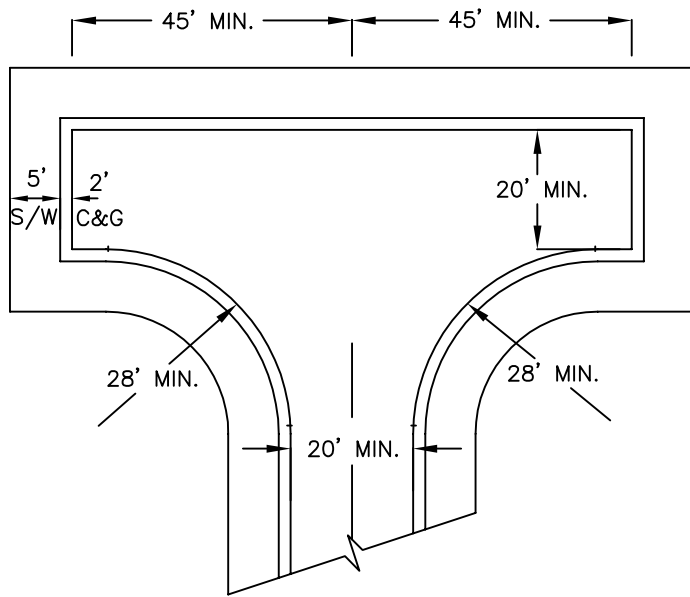

HAMMERHEAD

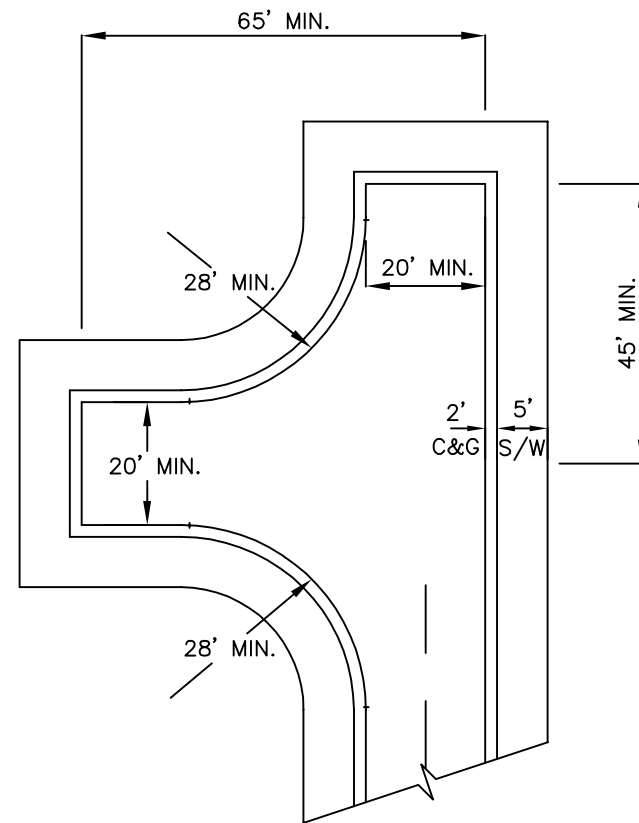

MODIFIED HAMMERHEAD

NOTES:

1. MINIMUM WIDTHS SHALL BE PER THE CITY STANDARD FOR CITY & PRIVATE ROADS AND 20' FOR ALL OTHER CIRCUMSTANCES.
2. CURB, GUTTER, AND SIDEWALKS SHALL BE INSTALLED ON CITY AND PRIVATE STREETS AND IN ALL OTHER CIRCUMSTANCES WHERE APPLICABLE.
3. ROLL CURBING MAY ALSO BE USED BUT A MINIMUM WIDTH OF 33.16 FROM B/C TO B/C MUST BE MAINTAINED.
4. DETACHED OR ATTACHED SIDEWALKS MAY BE USED.